

HWH CONTROL UNIT | ELECTRONIC

"CONTROL BOX" 310 SERIES

COMPUTER / TOUCH PANEL-CONTROLLED LEVELING SYSTEMS (Air, Hyd & Air/Hyd)
METAL/PLEXI GLASS BOX | 2.75" x 4.25" x 7.00"

(File: MR152000.DOC | Revised: 07JUN18)

[Print Friendly PDF File](#)

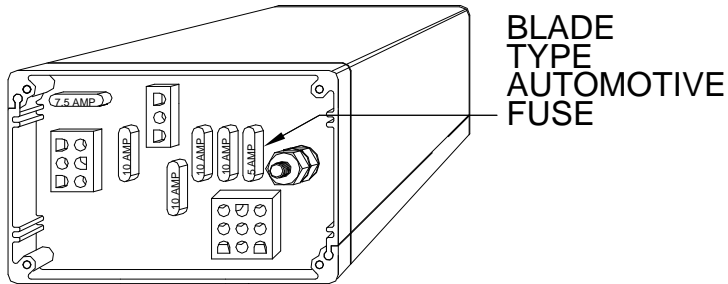

BLADE
TYPE
AUTOMOTIVE
FUSE

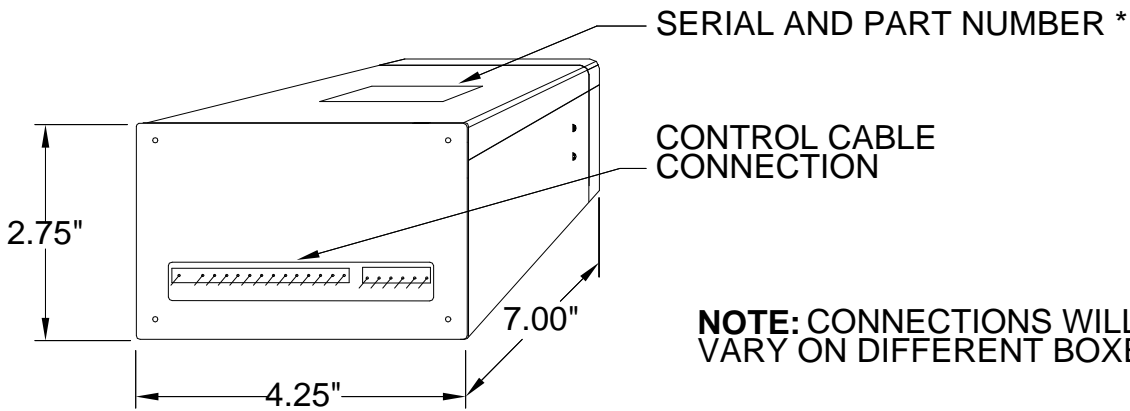

NOTE: CONNECTIONS WILL VARY ON DIFFERENT BOXES.

REPLACEMENT CONTROL BOXES

*EXISTING NUMBER	HYDRAULIC LEVELING	JACK STYLE	AIR DUMP	AIR LEVELING	PARK SIGNAL	OPERATION FEATURES	COMMON APPLIC.	REPLACE NUMBER
AP1220	YES	STR	NO	NO	NEG.	3 POINT	SAFARI	RAP1220
AP10050	YES	STR	YES	NO	NEG.	3 POINT	BEAVER	RAP90017
AP10079	YES	ANY	YES	NO	NEG.	BI-AXIS		RAP90019
AP10086	YES	ANY	NO	NO	NEG.	BI-AXIS		RAP90019
AP17403	YES	ANY	YES	NO	NEG.	PILOT AIR DUMP		RAP90536

* PART NUMBER IS ON TOP OF BOX. NUMBER BEGINS WITH "AP" FOLLOWED BY 4 OR 5 NUMERALS.