

# HWH CONTROL UNIT | ELECTRONIC

## "CONTROL BOX" 310 SERIES

COMPUTER / TOUCH PANEL-CONTROLLED LEVELING SYSTEMS (Air, Hyd & Air/Hyd)  
METAL/PLEXI GLASS BOX | 2.75" x 4.25" x 7.00"

(File: MR153000.DOC | Revised: 07JUN18)

[Print Friendly PDF File](#)

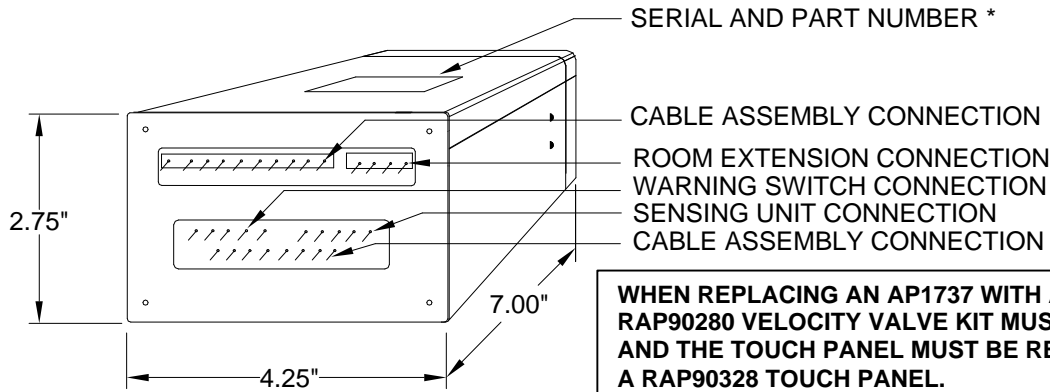
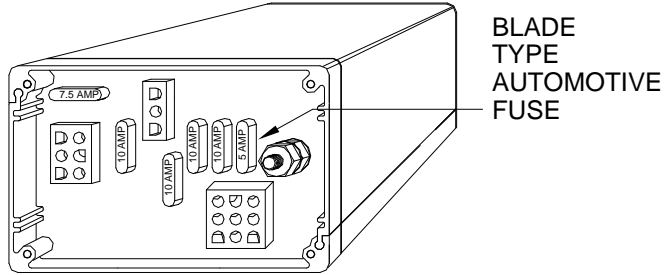

**WHEN REPLACING AN AP1737 WITH A RAP90327, A RAP90280 VELOCITY VALVE KIT MUST BE INSTALLED, AND THE TOUCH PANEL MUST BE REPLACED WITH A RAP90328 TOUCH PANEL.**

### REPLACEMENT CONTROL BOXES

*EXISTING NUMBER	HYDRAULIC LEVELING	JACK STYLE	AIR DUMP	AIR LEVELING	PARK SIGNAL	OPERATION FEATURES	**COMMON APPLIC.	REPLACE NUMBER
AP1737	YES	STR	NO	NO	NONE	FIFTH WHEEL TRAILERS	<b>OBSOLETE</b>	RAP90327
AP10971	YES	STR	NO	NO	NONE		CARRIAGE	RAP90537
AP11995	YES	STR	NO	NO	NEG.	BI-AXIS FRONT JACKS PRESS. SW	FEATHERLITE	RAP90299
AP14545	YES	STR	NO	NO	NONE	FIFTH WHEEL TRAILERS	TRAILERS	RAP90327
AP20961	YES	STR	NO	NO	NEG.	1 ROOM EXTENSION	TRAILERS	RAP91628
AP29798	YES	STR	YES	NO	NONE		TRAILERS	RAP91996

\* PART NUMBER IS ON TOP OF BOX. NUMBER BEGINS WITH "AP" FOLLOWED BY 4 OR 5 NUMERALS.

\*\* SOME VEHICLES MAY HAVE DIFFERENT CONTROL BOXES.