

HWH CONTROL UNIT | ELECTRONIC

"CONTROL BOX" 610 SERIES

COMPUTER / TOUCH PANEL-CONTROLLED LEVELING SYSTEMS (Air, Hyd & Air/Hyd)
METAL/PLEXI GLASS BOX | 2.75" x 4.25" x 8.00"

(File: MR154600.DOC | Revised: 29MAR19)

[Print Friendly PDF File](#)

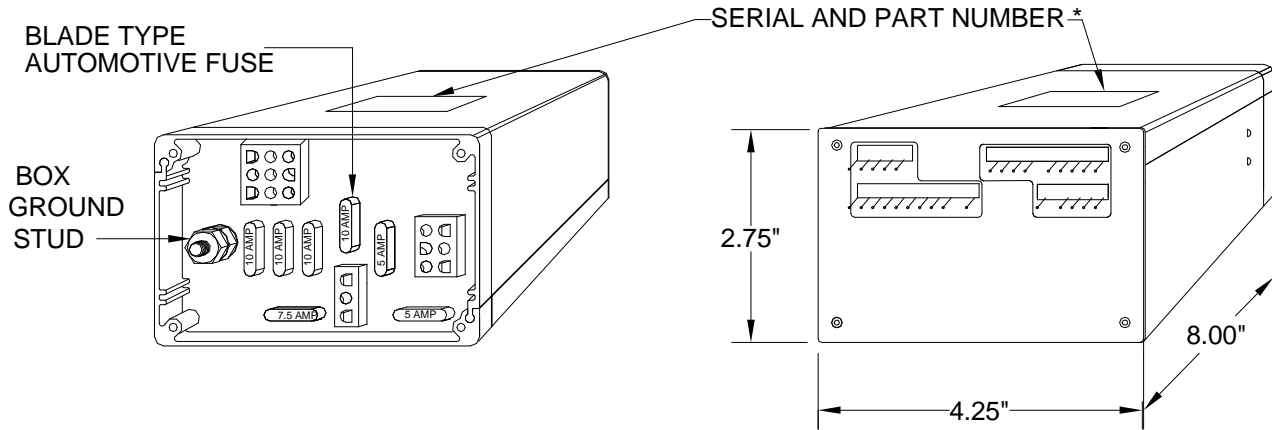

REPLACEMENTS:

- > NEW OR REMANUFACTURED UNITS ARE NO LONGER AVAILABLE.
- > HWH MAY BE ABLE TO REPAIR YOUR EXISTING UNIT.
- > CONTACT HWH TO GET AN RGA NUMBER TO RETURN THE EXISTING UNIT TO HWH FOR REPAIR.

REPLACEMENT CONTROL BOXES

*EXISTING NUMBER	HYDRAULIC LEVELING	JACK STYLE	AIR DUMP	AIR LEVELING	PARK SIGNAL	OPERATION FEATURES	**COMMON APPLIC.	REPLACE NUMBER (R & R ONLY)
AP0984	YES	4-KD	NO	NO	NEG.			RAP0984
AP1079	YES	4-ST	YES	NO	NEG.			RAP1079
AP1111	YES	4-ST	NO	NO	NEG.		NEWMAR COACHMAN	RAP1111
AP1227	YES	4-KD	YES	NO	NEG.	2-9000 # 2-16000 #		RAP1227
AP1290	YES	4-KD	NO	NO	NEG.	2-9000 # 2-16000 #		RAP1290
AP1292	YES	4-KD	YES	NO	NEG.			RAP1292
AP1503	YES	SPEC.	YES	NO	NEG.	UNIBODY	FORETRAVEL	RAP1503
AP1757	YES	4-KD	NO	NO	POS.	2-9000 # 2-16000 #		RAP1757
AP2078	YES	4-ST	NO	NO	NEG.	SINGLE JACK	NASA	RAP2078
AP2219	YES	4-ST	YES	NO	NEG.		MOEX	RAP90529
AP10089	YES	4-ST	NO	NO	POS.		EAGLE BUS	RAP90532
AP10284	YES	4-ST	YES	NO	NEG.			RAP91995
AP12209	YES	4-ST	YES	NO	NEG.	PILOT AIR DUMP	WINNEBAGO	RAP90304
AP16963	YES	4-ST	YES	NO	NEG.	PILOT AIR DUMP		RAP90533
AP18482	YES	4-ST	YES	NO	NEG.		NEWMAR	RAP90534

* PART NUMBER IS ON TOP OF BOX. NUMBER BEGINS WITH "AP" FOLLOWED BY 4 OR 5 NUMERALS.

** SOME VEHICLES MAY HAVE DIFFERENT CONTROL BOXES.